	TOWER-A	6 METER DIA.
	TOWER-B	3 METER DIA.

- NOTES & INFORMATION**
- ALL DIMENSIONS ARE INDICATED IN MILLIMETERS UNLESS OTHERWISE SPECIFIED.
 - DIMENSIONS TO BE READ AND NOT MEASURED.
 - ANY DISCREPANCY FOUND SHALL BE BROUGHT TO THE NOTICE OF THE ARCHITECTS / ENGINEERS.
 - ALL DRAWINGS TO BE READ IN CONJUNCTION WITH RELEVANT STRUCTURAL, ARCHITECTURAL AND SERVICES DRAWINGS.
 - THE DRAWING CANNOT BE FULLY AND CORRECTLY INTERPRETED WITHOUT REFERENCE TO SYMBOLS, SCHEDULES, ABBREVIATIONS AND SPECIFICATIONS

VILLAGE THERA

VILLAGE PILKHI

VILLAGE MUDAFARPUR

VILLAGE KUBADI

VILLAGE JATI BHAGVANPUR

- | | |
|---------------------------------------|---|
| 1. Main Entry | 19. Faculty Club |
| 2. Site Office/campus Outreach Center | 20. Commercial Market, Bank and Post Office |
| 3. Entrance Plaza | 21. Sports Field |
| 4. Academic Area | 22. School and Creche |
| 5. Administration Block | 23. Student Housing |
| 6. Communication Center | 24. Dining |
| 7. Museum | 25. Elevated Service Reservoir |
| 8. Campus Inn | 26. Kamal Sagar |
| 9. International Center | 27. Brick Making Yard |
| 10. Fire Station | 28. Labour Colony |
| 11. Faculty Housing | 29. Parking |
| 12. Library | 30. Green Houses |
| 13. Amphitheatre | 31. Nursery |
| 14. Campus Amenities | 32. Other Entries |
| 15. Student Center | 33. Substation (7 Nos.) |
| 16. Sports Center | 34. Main Receiving Station |
| 17. Central PV Station | 35. DEWAT System |
| 18. Faculty Club | |
| 19. Infirmary | |

0 25 50 100M

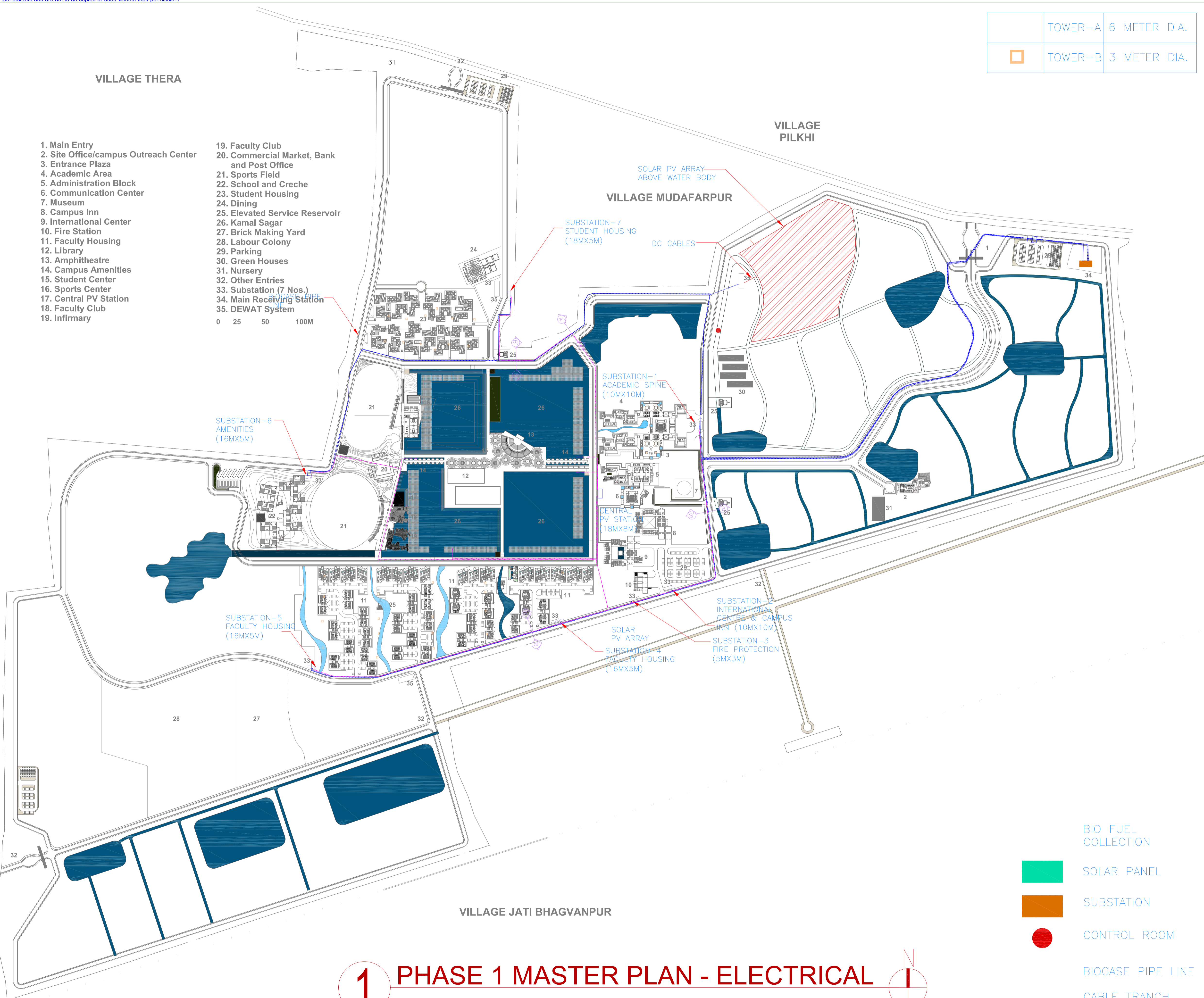

No.	Date	Remarks
Revisions		

Date	Prints	Issued to	Date	Prints	Issued to
Distribution of Prints					

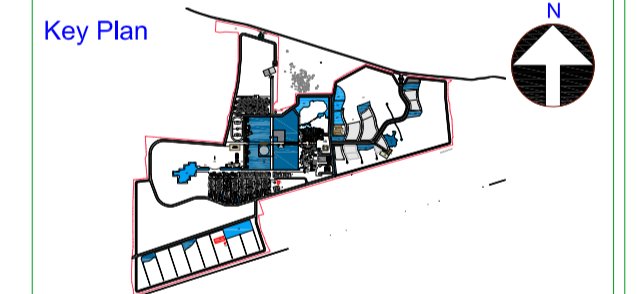

- Consultants**
- Structural Consultants**
VR SHAH Consulting Engineers
 - Services Consultants**
dbHMS
2nd Floor, D-68, Sector-2,
Noida - 201301
www.dbhms.in
 - Landscape Consultants**
Earthscapes Consultancy Pvt Ltd
 - Road and Pathways Consultants**
Arhmm Infra Consultants LLP

Project
Nalanda University, Rajgir, Bihar

Title
PHASE 1 MASTER PLAN - ELECTRICAL
FOR TENDER





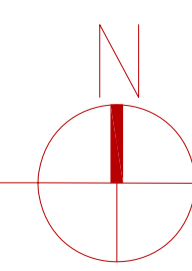

Dealt : HS	Drawing No.
Checked : MT	NUC(1)-MP-E-E2.0
Scale : 1:2500	
Date : 2014.05.15	

VASTU SHILPA CONSULTANTS
Architects | Planners | Urban Designers

"Sangath", Thaltej Road, Ahmedabad - 380054
Phone: 079 - 27454537 Fax: 079 - 27452006
www.sangath.org e-mail: vsc@sangath.org

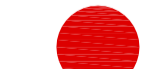
1 PHASE 1 MASTER PLAN - ELECTRICAL



-  BIO FUEL COLLECTION
-  SOLAR PANEL
-  SUBSTATION
-  CONTROL ROOM
-  BIOGASE PIPE LINE
-  CABLE TRANCH



SR.	MARK	DESCRIPTION	CAPACITY
1	DW-1	WASTE WATER TREATMENT PLANT	42KLD
2	DW-2	WASTE WATER TREATMENT PLANT	96KLD
3	DW-3	WASTE WATER TREATMENT PLANT	76KLD
3	DW-4	WASTE WATER TREATMENT PLANT	20KLD
4	ESR-1	OVER HEAD WATER STORAGE	60KL
5	ESR-2	OVER HEAD WATER STORAGE	60KL
6	ESR-3	OVER HEAD WATER STORAGE	60KL
7	ESR-4	OVER HEAD WATER STORAGE	60KL
8	ESR-5	OVER HEAD WATER STORAGE	60KL
9	T-1	CENTRAL TREATMENT STATION	450CUM
10	T-2	UG DRINKING WATER TREATMENT STATION (STUDENT HOUSING)	780CUM
11	T-3	UG DRINKING WATER TREATMENT STATION (ACADEMIC SPINE)	1400CUM
12	T-4	UG DRINKING WATER TREATMENT STATION (FACULTY HOUSING)	1400CUM
13	T-5	UG DRINKING WATER TREATMENT STATION (CAMPUS AMENITIES)	900CUM

1 Master Plan: Fire Fighting

No.	Date.	Remarks.
-----	-------	----------

Revisions		

Date	Prints	Issued to	Date	Prints	Issued to
15.7.16	A1	VSC			

Distribution of Prints

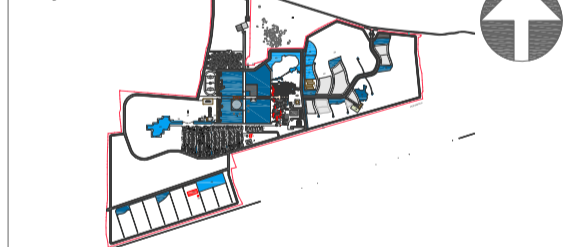

- Consultants
- Structural Consultants
VR SHAH Consulting Engineers
 - Services Consultants
dbHMS
2nd Floor, D-62, Sector-2,
Noida - 201301
www.dbhms.in
 - Landscape Consultants
Earthscapes Consultancy Pvt Ltd
 - Road and Pathways Consultants
Arhmm Infra Consultants LLP

Project
Nalanda University, Rajgir, Bihar

Title
MASTER PLAN - FIRE FIGHTING
FOR TENDER

Dealt : JK	Drawing No.
Checked : AT	NUC-MP-P-FF2.4
Scale : 1:2500	
Date : 15.07.2016	Approved: VM

VASTU SHILPA CONSULTANTS
Architects | Planners | Urban Designers

Sangath, Thaltej Road, Ahmedabad - 380054
Phone: 079 - 27454537 Fax: 079 - 27452006
www.sangath.org e-mail: vsc@sangath.org

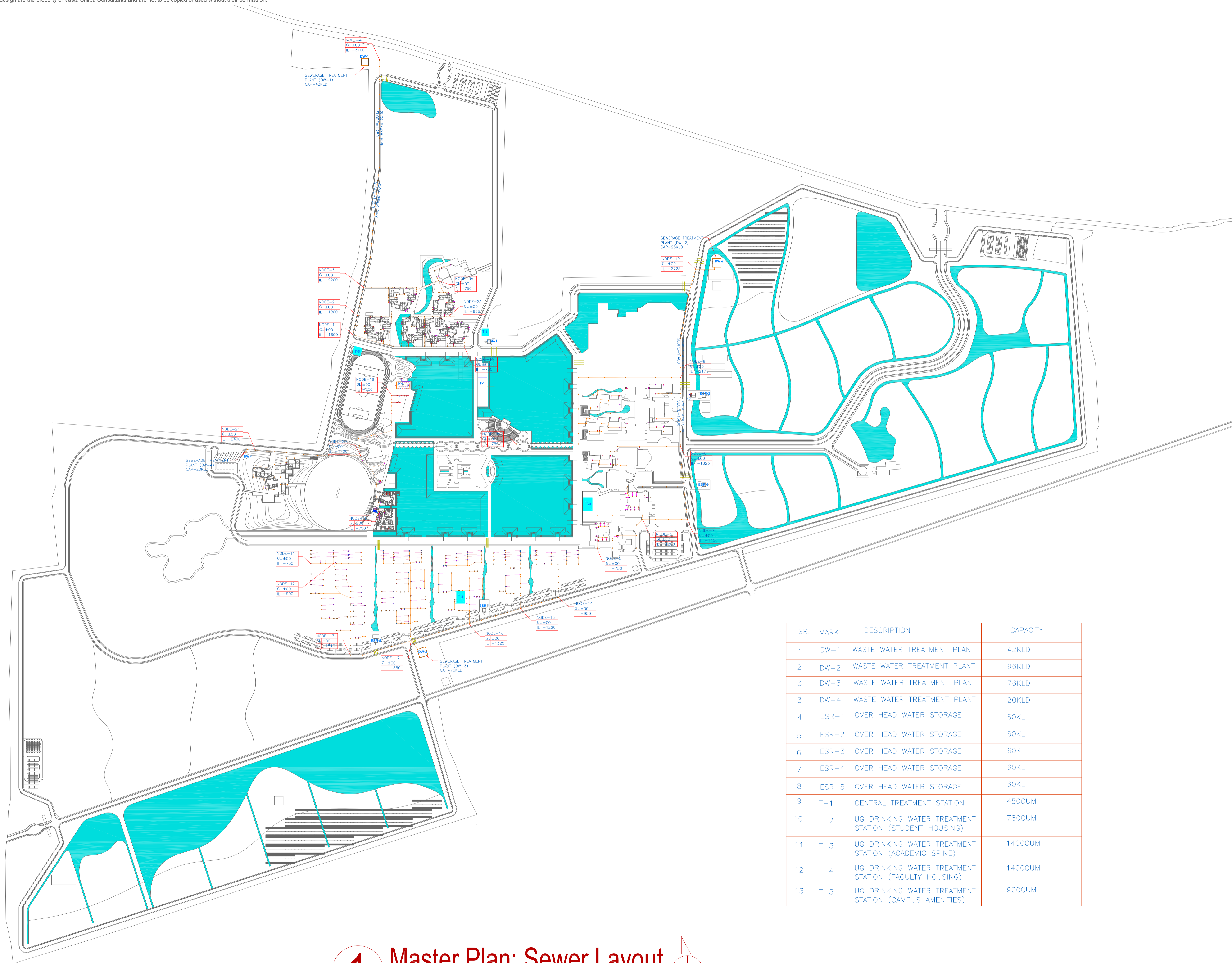

SR.	MARK	DESCRIPTION	CAPACITY
1	DW-1	WASTE WATER TREATMENT PLANT	42KLD
2	DW-2	WASTE WATER TREATMENT PLANT	96KLD
3	DW-3	WASTE WATER TREATMENT PLANT	76KLD
3	DW-4	WASTE WATER TREATMENT PLANT	20KLD
4	ESR-1	OVER HEAD WATER STORAGE	60KL
5	ESR-2	OVER HEAD WATER STORAGE	60KL
6	ESR-3	OVER HEAD WATER STORAGE	60KL
7	ESR-4	OVER HEAD WATER STORAGE	60KL
8	ESR-5	OVER HEAD WATER STORAGE	60KL
9	T-1	CENTRAL TREATMENT STATION	450CUM
10	T-2	UG DRINKING WATER TREATMENT STATION (STUDENT HOUSING)	780CUM
11	T-3	UG DRINKING WATER TREATMENT STATION (ACADEMIC SPINE)	1400CUM
12	T-4	UG DRINKING WATER TREATMENT STATION (FACULTY HOUSING)	1400CUM
13	T-5	UG DRINKING WATER TREATMENT STATION (CAMPUS AMENITIES)	900CUM

1 Master Plan: Sewer Layout

No.	Date.	Remarks.			
Revisions					
15.7.16	A1	VSC			
Date	Prints	Issued to	Date	Prints	Issued to

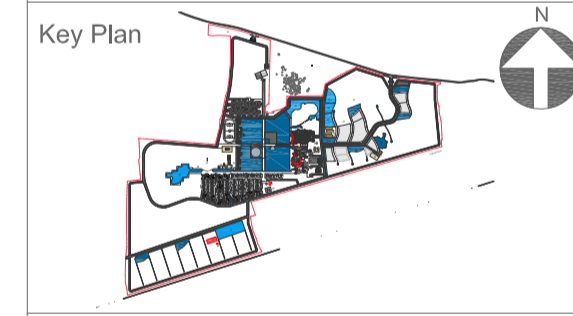

- Consultants
- Structural Consultants**
VR SHAH Consulting Engineers
 - Services Consultants**
dbHMS
2nd Floor, D-42, Sector -2,
Noida - 201301
www.dbhms.in
 - Landscape Consultants**
Earthscapes Consultancy Pvt Ltd
 - Road and Pathways Consultants**
Arhmm Infra Consultants LLP

Project
Nalanda University, Rajgir, Bihar

Title
MASTER PLAN - SEWER LAYOUT
DRAFT TENDER

Dealt : JK	Drawing No.
Checked : AT	NUC-MP-P-P2.1
Scale : 1:2500	
Date : 15.07.2016	Approved: VM

VASTU SHILPA CONSULTANTS
Architects | Planners | Urban Designers

Sangath, Thaltej Road, Ahmedabad - 380054
Phone: 079 - 27454537 Fax: 079 - 27452006
www.sangath.org e-mail: vsc@sangath.org

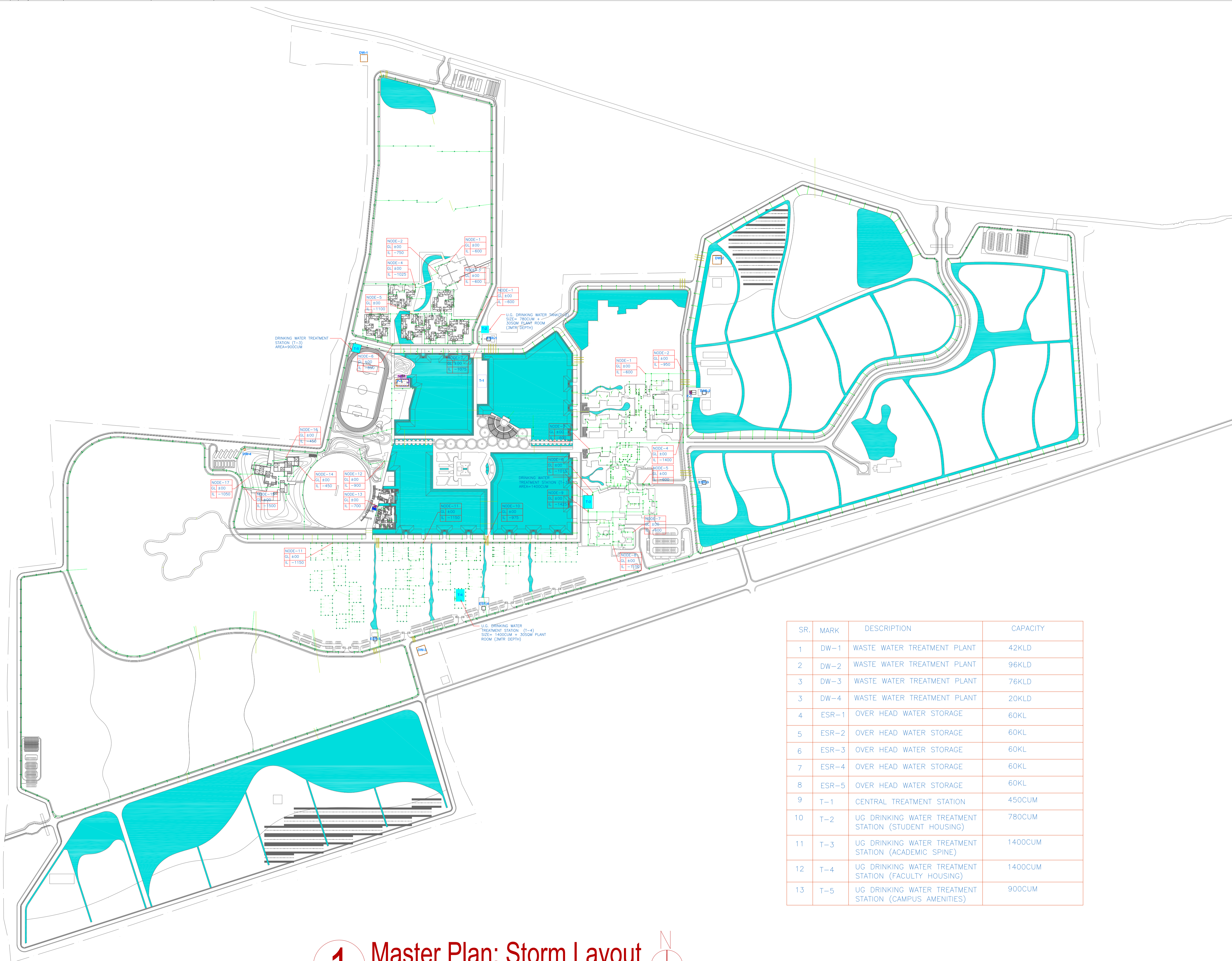

SR.	MARK	DESCRIPTION	CAPACITY
1	DW-1	WASTE WATER TREATMENT PLANT	42KLD
2	DW-2	WASTE WATER TREATMENT PLANT	96KLD
3	DW-3	WASTE WATER TREATMENT PLANT	76KLD
3	DW-4	WASTE WATER TREATMENT PLANT	20KLD
4	ESR-1	OVER HEAD WATER STORAGE	60KL
5	ESR-2	OVER HEAD WATER STORAGE	60KL
6	ESR-3	OVER HEAD WATER STORAGE	60KL
7	ESR-4	OVER HEAD WATER STORAGE	60KL
8	ESR-5	OVER HEAD WATER STORAGE	60KL
9	T-1	CENTRAL TREATMENT STATION	450CUM
10	T-2	UG DRINKING WATER TREATMENT STATION (STUDENT HOUSING)	780CUM
11	T-3	UG DRINKING WATER TREATMENT STATION (ACADEMIC SPINE)	1400CUM
12	T-4	UG DRINKING WATER TREATMENT STATION (FACULTY HOUSING)	1400CUM
13	T-5	UG DRINKING WATER TREATMENT STATION (CAMPUS AMENITIES)	900CUM

1 Master Plan: Storm Layout

No.	Date.	Remarks.
Revisions		
15.7.16	A1	VSC
Date	Prints	Issued to
Date	Prints	Issued to

Distribution of Prints

Key Plan

Consultants

- Structural Consultants
VR SHAH Consulting Engineers
- Services Consultants
dbHMS
2nd Floor, D-42, Sector-2,
Noida - 201301
www.dbhms.in
- Landscape Consultants
Earthscapes Consultancy Pvt Ltd
- Road and Pathways Consultants
Arhmm Infra Consultants LLP

Project

Nalanda University, Rajgir, Bihar

Title

MASTER PLAN - STORM LAYOUT FOR TENDER

Dealt : JK	Drawing No.
Checked : AT	NUC-MP-P-P2.2
Scale : 1:2500	
Date : 15.07.2016	Approved: VM

VASTU SHILPA CONSULTANTS
Architects | Planners | Urban Designers

'Sangath', Thaltej Road, Ahmedabad - 380054
Phone: 079 - 27454537 Fax: 079 - 27452006
www.sangath.org e-mail: vsc@sangath.org

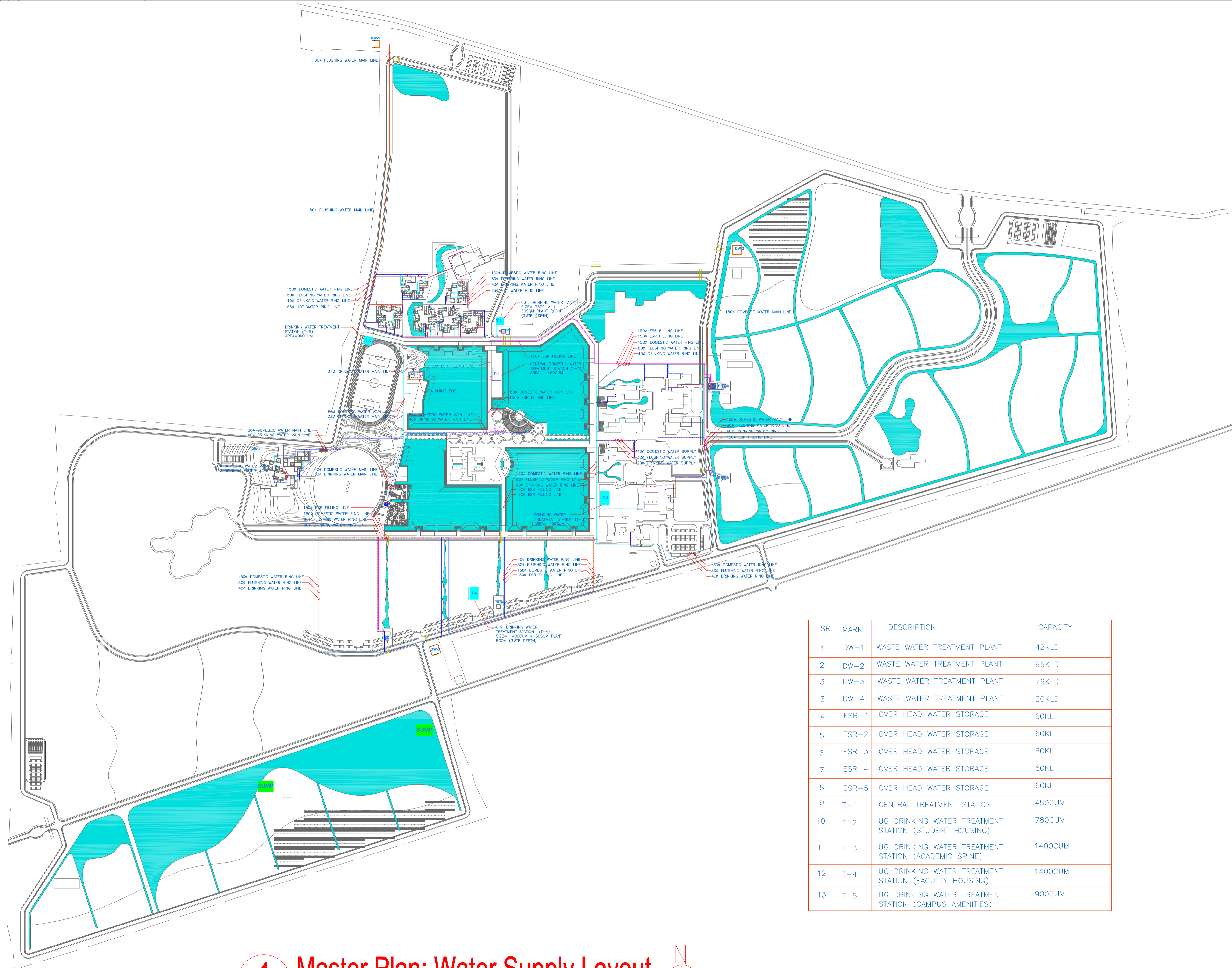

1 Master Plan: Water Supply Layout

SR.	MARK	DESCRIPTION	CAPACITY
1	DW-1	WASTE WATER TREATMENT PLANT	42KLD
2	DW-2	WASTE WATER TREATMENT PLANT	96KLD
3	DW-3	WASTE WATER TREATMENT PLANT	76KLD
3	DW-4	WASTE WATER TREATMENT PLANT	20KLD
4	ESR-1	OVER HEAD WATER STORAGE	60KL
5	ESR-2	OVER HEAD WATER STORAGE	60KL
6	ESR-3	OVER HEAD WATER STORAGE	60KL
7	ESR-4	OVER HEAD WATER STORAGE	60KL
8	ESR-5	OVER HEAD WATER STORAGE	60KL
9	T-1	CENTRAL TREATMENT STATION	450CUM
10	T-2	UG DRINKING WATER TREATMENT STATION (STUDENT HOUSING)	780CUM
11	T-3	UG DRINKING WATER TREATMENT STATION (ACADEMIC SPINE)	1400CUM
12	T-4	UG DRINKING WATER TREATMENT STATION (FACULTY HOUSING)	1400CUM
13	T-5	UG DRINKING WATER TREATMENT STATION (CAMPUS AMENITIES)	900CUM

No.	Date.	Remarks.
Revisions		

Date	Prints	Issued to	Date	Prints	Issued to
15.7.16	A1	VSC			

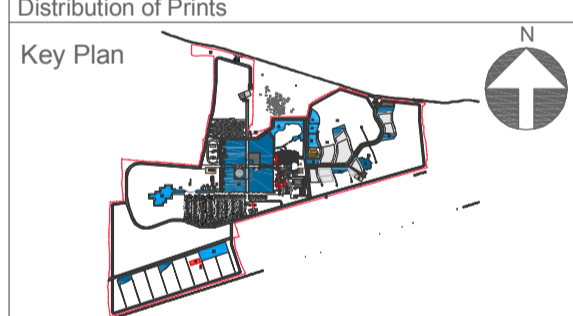

- Consultants
- Structural Consultants**
VR SHAH Consulting Engineers
 - Services Consultants**
dbHMS
2nd Floor, D-62, Sector -2,
Noida - 201301
www.dbhms.in
 - Landscape Consultants**
Earthscapes Consultancy Pvt Ltd
 - Road and Pathways Consultants**
Arhmm Infra Consultants LLP

Project

Nalanda University, Rajgir, Bihar

Title

MASTER PLAN - WATER SUPPLY LAYOUT

DRAFT TENDER

Dealt : JK	Drawing No.
Checked : AT	NUC-MP-P-P2.3
Scale : 1:2500	
Date : 15.07.2016	Approved: VM

VASTU SHILPA CONSULTANTS
Architects | Planners | Urban Designers

'Sangath', Thaltej Road, Ahmedabad - 380054
Phone: 079 - 27454537 Fax: 079 - 27452006
www.sangath.org e-mail: vsc@sangath.org

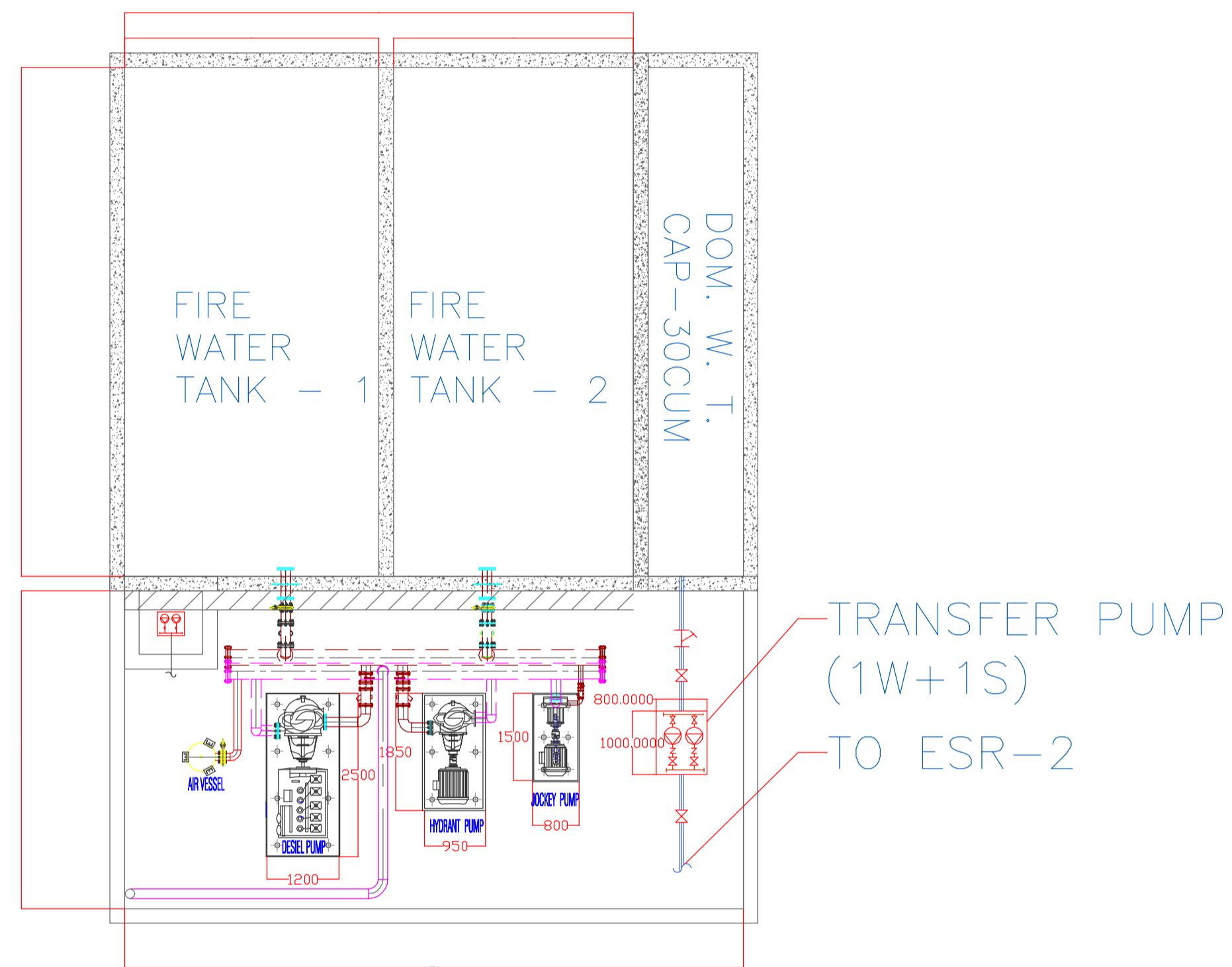

PLANT ROOM – (F1)

DOMESTIC WATER TANK SIZE – 8Mx1.5Mx3.5M(DEEP)

DOMESTIC WATER TANK CAP – 30CUM

FIRE WATER TANK SIZE – 8Mx8Mx3.5M(DEEP)

FIRE WATER TANK CAP – 110KL (2NOS.)

PUMP ROOM SIZE – 9.7Mx5Mx3.5M(DEEP)

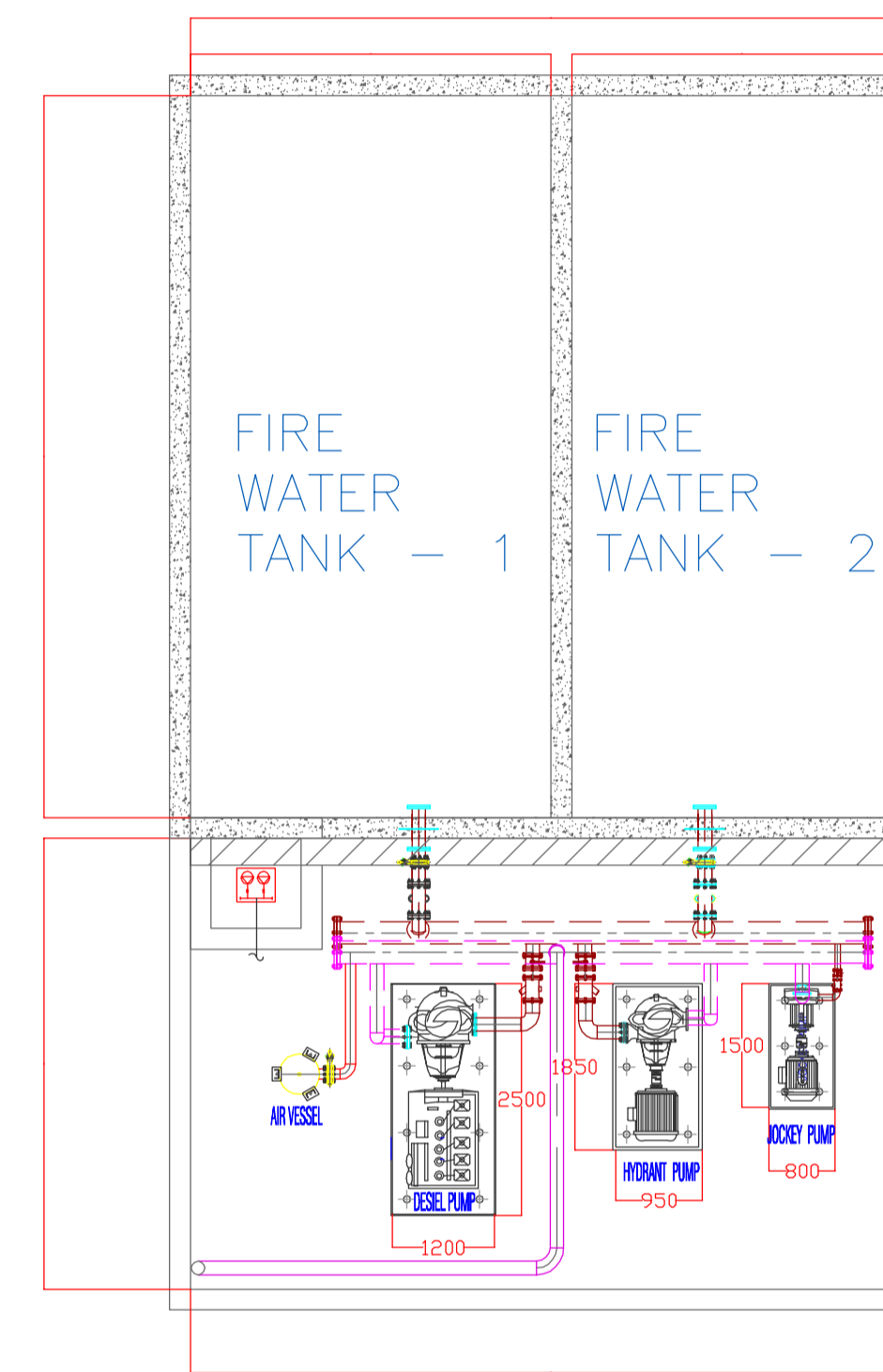

FIRE PLANT ROOM – (F2)

FIRE WATER TANK SIZE – 8Mx8Mx3.5M(DEEP)

FIRE WATER TANK CAP. – 110KL (2NOS.)

TREATMENT STATION SIZE – 8Mx5Mx3.5M(DEEP)

No.	Date.	Remarks.
-----	-------	----------

Revisions

15.7.16	AT	VSC
---------	----	-----

Date	Prints	Issued to	Date	Prints	Issued to
------	--------	-----------	------	--------	-----------

Distribution of Prints

Key Plan

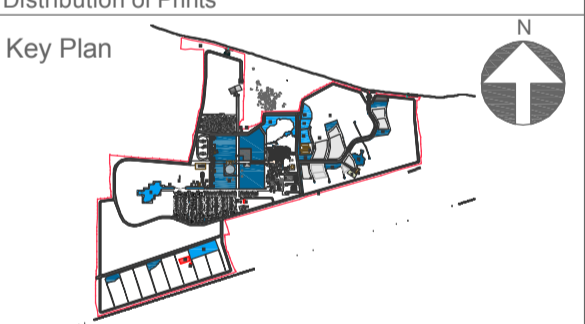

Consultants

○ **Structural Consultants**
VR SHAH Consulting Engineers

○ **Services Consultants**

dbHMS
2nd Floor, D-62, Sector
-2,
Noida - 201301
www.dbhms.in

○ **Landscape Consultants**
Earthscapes Consultancy Pvt Ltd

○ **Road and Pathways Consultants**
Arhmm Infra Consultants LLP

Project

Nalanda University, Rajgir, Bihar

Title

ENLARGE PLANT ROOM – PLUMBING
FOR TENDER

Dealt : JK

Checked : AT

Scale : 1:50

Date : 15.07.2016

Drawing No.

NUC(1)-MP-P-P3.1

Approved: VM

VASTU SHILPA CONSULTANTS
Architects | Planners | Urban Designers

"Sangath", Thaltej Road, Ahmedabad - 380054
Phone: 079 - 27454537 Fax: 079 - 27452006
www.sangath.org e-mail: vsc@sangath.org

1 ENLARGE PLANT ROOM
Scale - 1:50

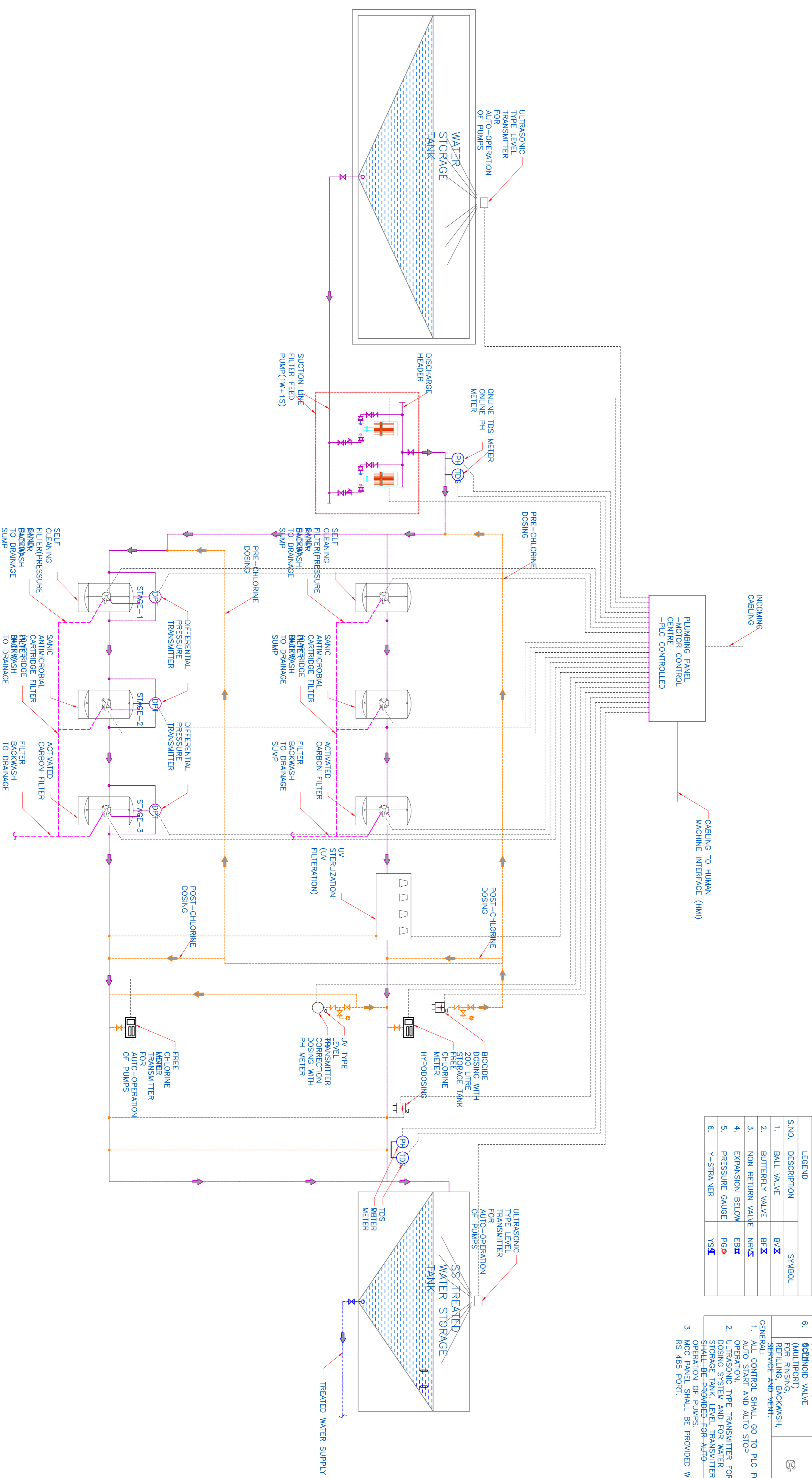

S.NO.	DESCRIPTION	SYMBOL
1.	BALL VALVE	B.V.
2.	BUTTERFLY VALVE	B.F.V.
3.	NON RETURN VALVE	N.R.V.
4.	EXPANSION BELOW	E.B.
5.	PRESSURE GAUGE	P.G.
6.	Y-STRAINER	Y.S.

S.NO.	DESCRIPTION	SYMBOL
1.	TDS METER RANGE- 500PPM (INLET) 30-50 PPM (OUTLET) SHALL AT 50 LPM	
2.	PH METER RANGE- 7-8.5	
3.	DIFFERENTIAL PRESSURE TRANSMITTER RANGE- < 1 KG/CW*2	
4.	ALL FILTER SHALL BACKWASH AND BACKWASH WATER DRAINAGE (BACKWASH) LITRES	
5.	BIOWASHING CAPACITY T.M.DOSING LITRES 200	
6.	DOSEING CAPACITY BACKWASH VALVE FOR DRINKING WATER REFINING, BACKWASH, SERVICE AND VENT.	

GENERAL CONTROL SHALL GO TO PLC FOR AUTO START AND AUTO STOP OPERATION. ULTRASONIC TYPE TRANSMITTER FOR STORAGE TANK LEVEL TRANSMITTER SHALL BE PROVIDED FOR AUTO OPERATION OF PUMPS. RS 485 PORT SHALL BE PROVIDED WITH RS 485 PORT.

1 Drinking Water Treatment Station Schematic: Plumbing

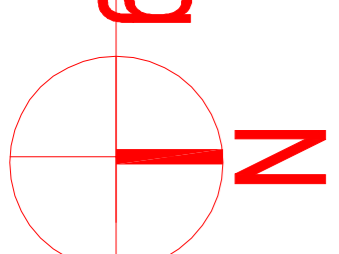

<p>Revisions</p> <table border="1" style="width: 100%; border-collapse: collapse;"> <thead> <tr> <th>No.</th> <th>Date</th> <th>Remarks</th> </tr> </thead> <tbody> <tr> <td>1</td> <td>15.7.16</td> <td>AT VSC</td> </tr> </tbody> </table> <p>Date Printed: Issued to: Date Printed: Issued to:</p> <p>Distribution of Prints</p> <p style="text-align: center;">NORTH</p>	No.	Date	Remarks	1	15.7.16	AT VSC	<p>Consultants</p> <ul style="list-style-type: none"> ○ Structural Consultants VR SHAH Consulting Engineers ○ Services Consultants dshims 2nd Floor, 1242 Sector-2, Vasant Vihar, Delhi-110067 ○ Landscape Consultants Earthscapes Consultancy Pvt Ltd ○ Road and Pathways Consultants Amm Infra Consultants LLP <p>Project: Nalanda University, Raigir, Bihar</p>
No.	Date	Remarks					
1	15.7.16	AT VSC					
<p>Title DRINKING WATER TREATMENT STATION SCHEMATIC : PLUMBING FOR TENDER</p> <p>Drawn By: JK Checked: AT Scale: NTS Date: 15.07.2016</p>	<p>Drawing No.: NUC-WP-P-P3.3 Approved By: VM</p> <p>VASTU SHILPA CONSULTANTS Architects Planners Urban Designers</p> <p>'Sanghvi', Thakur Road, Anandnagar, -80064 Phone: 079-27454537 Fax: 079-27452006 www.sanghvi.org e-mail: vsc@sanghvi.org</p>						

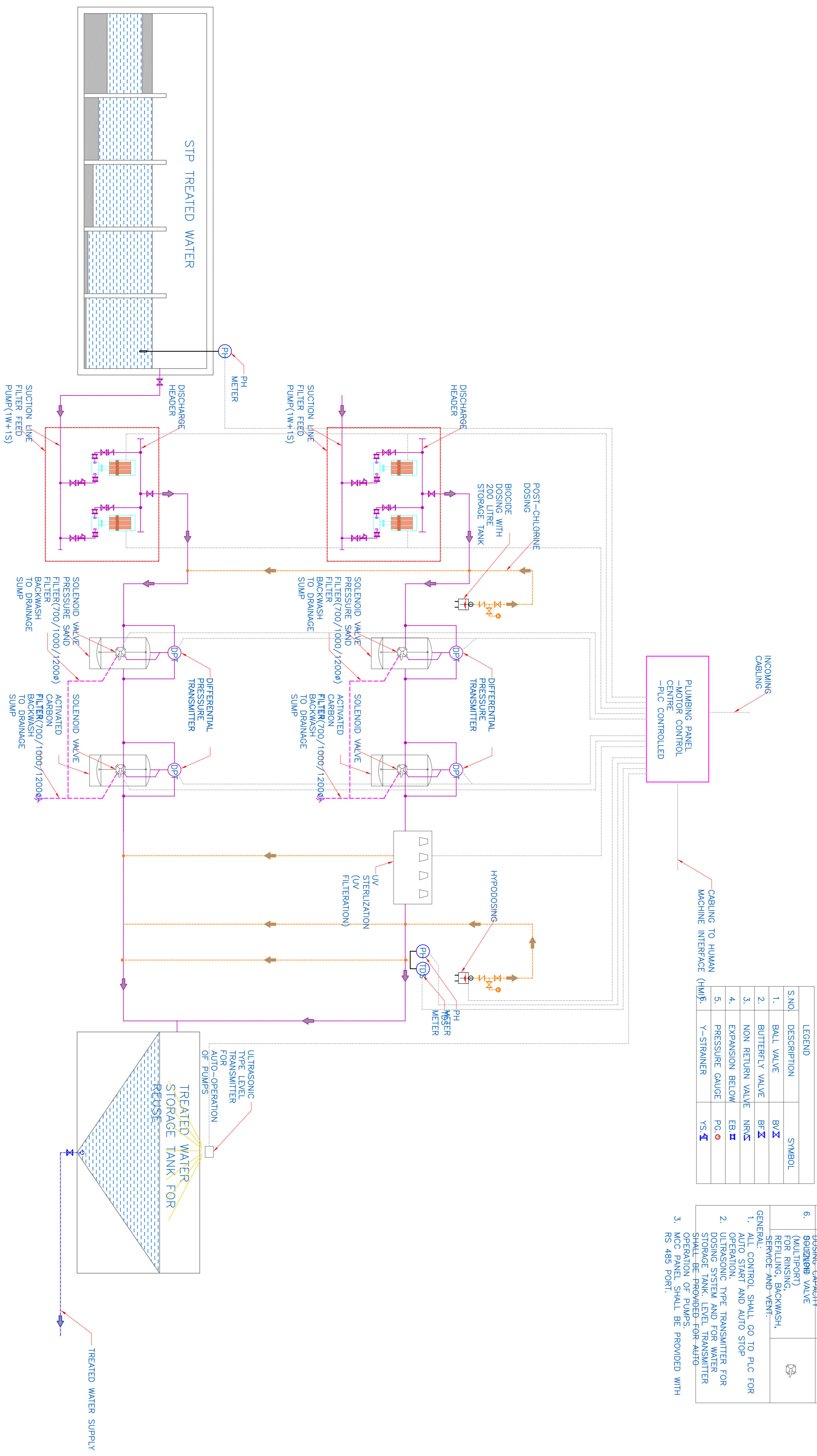

S.NO.	DESCRIPTION	SYMBOL
1.	BALL VALVE	BV
2.	BUTTERFLY VALVE	BF
3.	NON RETURN VALVE	NRV
4.	EXPANSION BELOW	EB
5.	PRESSURE GAUGE	PG
	Y-STRAINER	YS

S.NO.	DESCRIPTION	SYMBOL
1.	TDS METER RANGE- 500PPM (NILET) 30-50 ppm RANGE-ALUMINIUM	TDS
2.	PH METER RANGE- 7-8.5	PH
3.	DIFFERENTIAL PRESSURE TRANSMITTER RANGE- < 1 KG/CM ² (ALL FILTER SHALL BACKWASH AND BACKWASHING DRAINAGE TO DRAINAGE SUMP)	DP
4.	DOSEING CAPACITY BEHINDER VALVE (MULTIPORT) FOR RINSING, REFILLING, BACKWASH, SERVICE AND VENT.	
6.	GENERAL CONTROL SHALL GO TO PLC FOR 1. AUTO START AND AUTO STOP OPERATION. 2. ULTRASONIC TYPE TRANSMITTER FOR STORAGE TANK LEVEL TRANSMITTER OPERATION OF PUMP OR AUTO	
3.	MCC PANEL SHALL BE PROVIDED WITH RS 485 PORT.	

1 STP Water Treatment Station Schematic: Plumbing

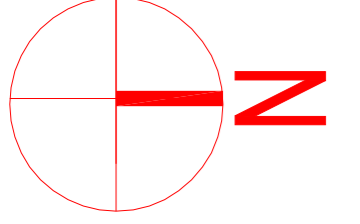

Consultants ○ Structural Consultants VR SHAH Consulting Engineers ○ Services Consultants dbhims 3rd Floor, 7th Sector-2, Vastu Shilpa www.dbhims.in ○ Landscape Consultants Earthscapes Consultancy Pvt Ltd ○ Road and Pathways Consultants Armm Infra Consultants LLP		No. _____ Date _____ Remarks _____ Revisions 15.7.16 AT VSC Date _____ Prints Issued to _____ Date _____ Prints Issued to _____ Distribution of Prints NORTH	
Project: Nalanda University, Raigir, Bihar		Title: STP WATER TREATMENT STATION SCHEMATIC : PLUMBING FOR TENDER	
Dearl : JK Checked : AT Scale : NTS Date : 15.07.2016		Drawing No. NUC-WP-P-P3.4 Approved By : VM	
VASTU SHILPA CONSULTANTS Architects Planners Urban Designers 'Sangam', Thakur Road, Anandnagar, -80064 Phone: 079-27464637 Fax: 079-27462006 www.sangamth.org e-mail: vsc@sangamth.org			

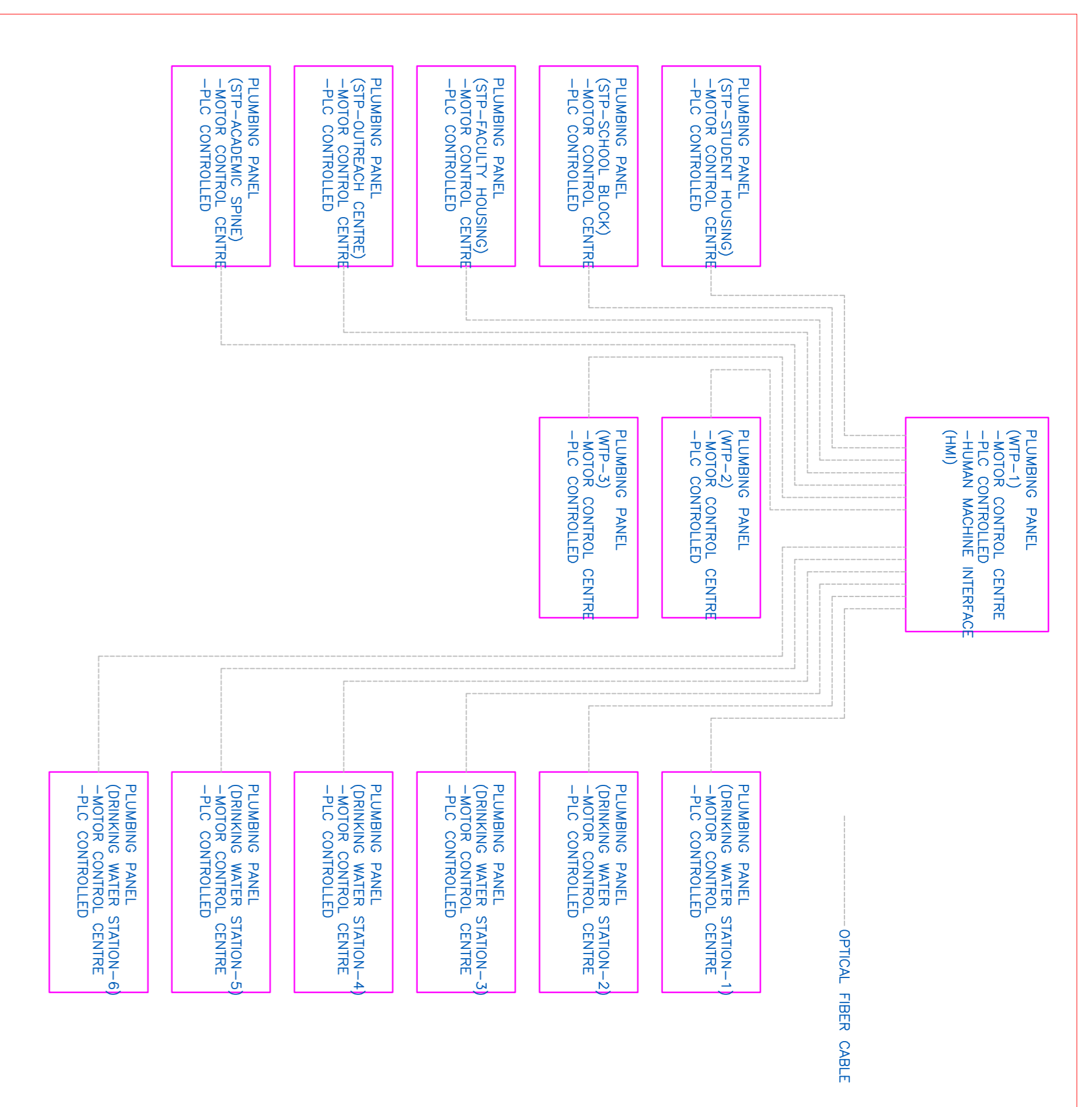

S.NO.	DESCRIPTION	SYMBOL
1.	BALL VALVE	BV
2.	BUTTERFLY VALVE	BF
3.	NON RETURN VALVE	NRV
4.	EXPANSION BELOW	EB
5.	PRESSURE GAUGE	PG
6.	Y-STRAINER	YS

S.NO.	DESCRIPTION	SYMBOL
1.	TDS METER RANGE - 30-50 PPM (OUTLET-ALARM AT 50 PPM)	TDS
2.	PH METER RANGE - 7-8.5	PH
3.	BIOCODE DOSING LITRES DOSING CAPACITY 0-12LPH	
4.	PH DOSING TANK CAP: 200 LITRES DOSING CAPACITY 0LPH	

GENERAL:
 1. ALL CONTROL SHALL GO TO PLC FOR AUTO START AND AUTO STOP OPERATION.
 2. ULTRASONIC TYPE TRANSMITTER FOR DOSING SYSTEM SHALL BE PROVIDED FOR AUTO OPERATION OF PUMPS.
 3. MCC PANEL SHALL BE PROVIDED WITH RS 485 PORT.

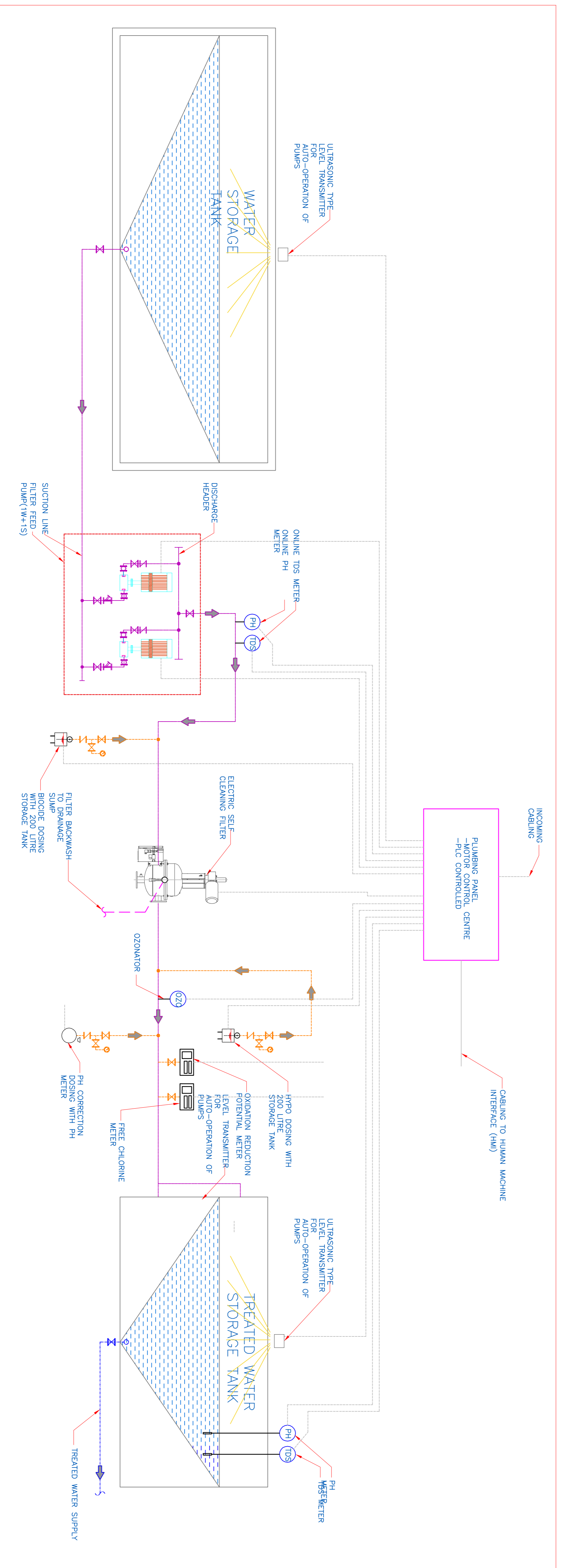

1 Domestic Water Treatment Station Schematic: Plumbing

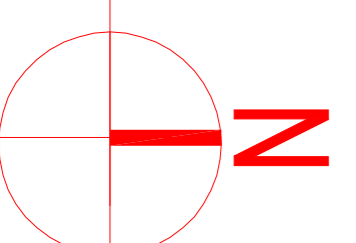

No.	Date	Remarks
Revisions		
15.7.16	AT	VSC
Date	Prints Issued to	Date
	Prints Issued to	

Distribution of Prints

Key Plan

- Consultants
- Structural Consultants
VR SHAH Consulting Engineers
 - Services Consultants
dbHMS
2nd Floor, Datta, Sector-2,
www.dbhms.in
 - Landscape Consultants
Earthscapes Consultancy Pvt Ltd
 - Road and Pathways Consultants
Ammi Infra Consultants LLP

Project
Nalanda University, Rajgir, Bihar

Title
 DOMESTIC WATER TREATMENT
 STATION SCHEMATIC - PLUMBING
 TENDER

Drawn No. NUC(1)-WTP-33.5
 Checked: AT
 Scale: N.T.S.
 Date: 15.07.2016
 Approved: VM

VASTU SHILPA CONSULTANTS
 Architects | Planners | Urban Designers

Sangrath, Thanej Road, Amethabad - 380034
 Phone: 079 27649337 fax: 079 27626208
 www.vastushilpa.com mail: vsc@vastushilpa.com